

Portfolio

- Design -



国際宇宙ステーション(ISS)インテリアデザイン案

小野 綾子

Ayako ONO

E-mail: sande.ayk@gmail.com

Tel: 080-5385-7187

現在使用可能なソフト等：

Photoshop

Illustrator

InDesign

PowerPoint

Wordpress



展示会用ポスターおよびDM 等デザイン

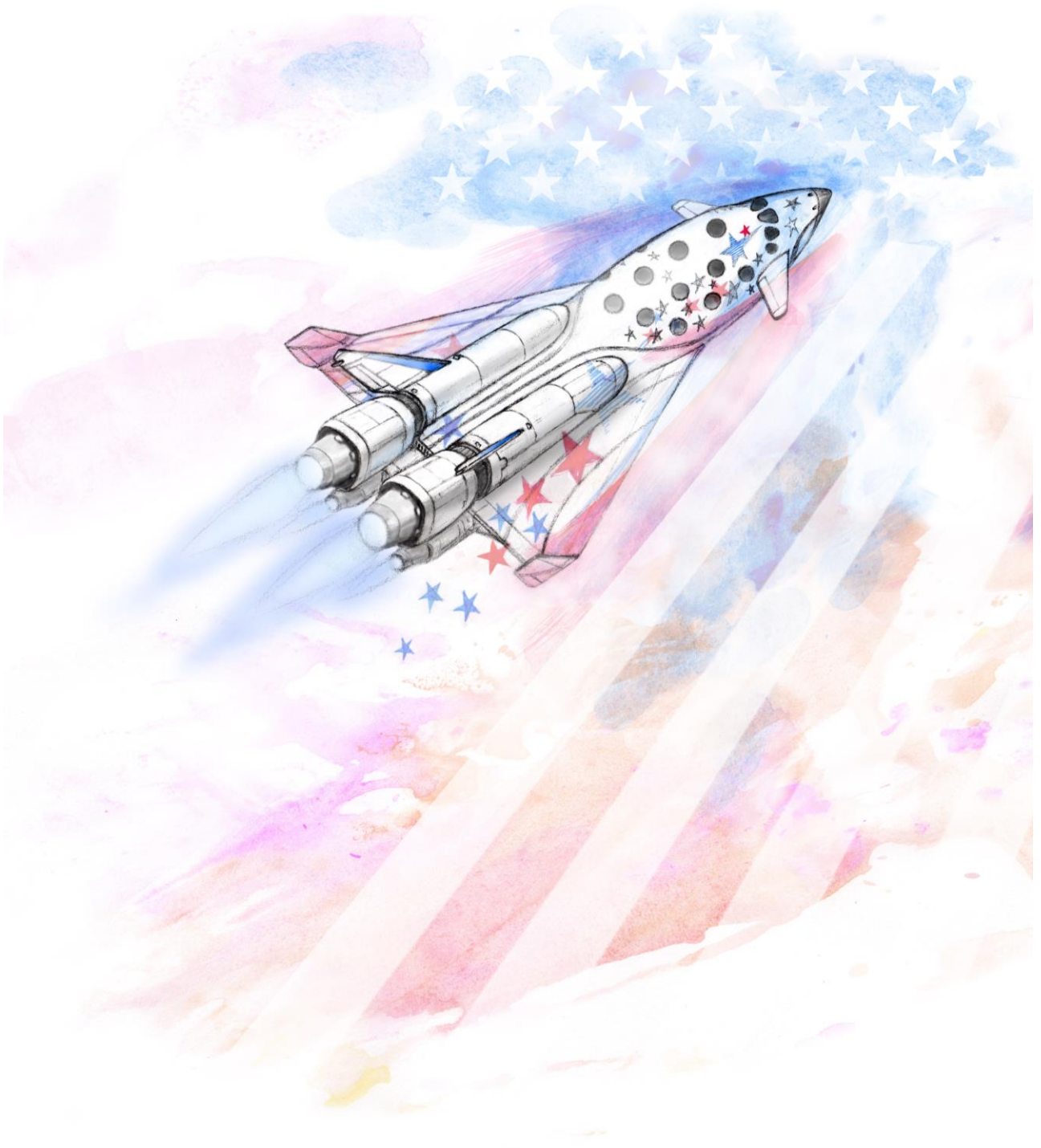

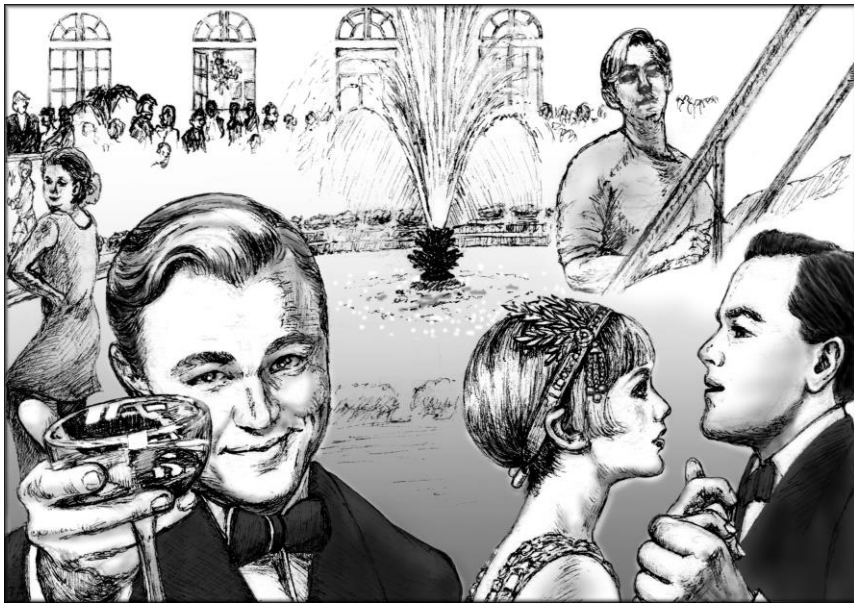

入門 アメリカ経済 Q&A 100 挿絵 手描きに Photoshop 加工

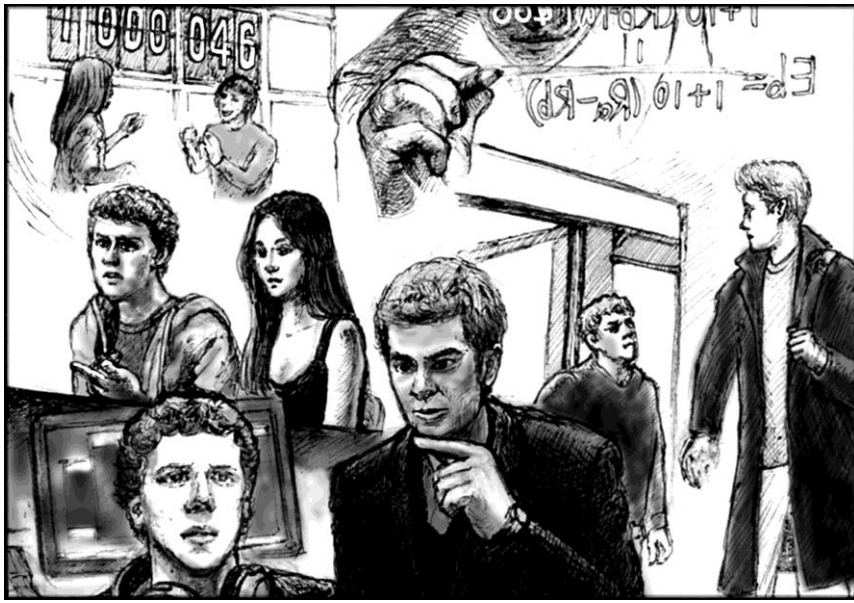



春雨銀河提案とセタイイベントでの提供



小惑星イトカワ 唐揚げデザイン提案とセタイイベントでの提供



Food Menu

Mars

- ベジタリアン・メニュー
- 数種類の豆と野菜のトマト味

火星



火星 アップ



木星

第10回 宇宙ユニット・シンプोजウム

宇宙にひろがる人類文明の未来

宇宙にひろがる人類文明の未来

宇宙における持続可能な社会構築

2017

関連イベント

2.10 金 18:00-20:00
 京都大学国際芸術フォーラム
 京都大学百周年時計台記念館1階 時計台記念ホール
 奇跡への挑戦—未来創成学と宇宙総合学からの展望
 高跡への挑戦—未来創成学「古事記と宇宙」
 会場◎京都大学 未来創成学国際研究ユニット
 1. 夏多郎さんによる映像ライブ演奏「古事記と宇宙」 村瀬雅隆 (司会)
 2. パネル討論：夏多郎、佐々木剛、柴田一成、村瀬雅隆
 主催◎京都大学 未来創成学国際研究ユニット
 共催◎宇宙総合学研究ユニット

2.11 土 13:00-17:00
 「宇宙研究の広場」ポスター展示発表
 会場◎京都大学百周年時計台記念館2階
 国際交流ホール (吉田キャンパス本部棟内)
 宇宙研究の広場とは... 宇宙開発者、研究者、大学院生、大学生、市民のみならず、全ての来場者が交流する場です。様々な研究や取り組みをポスター展示で紹介いたします。お気軽にご参加下さい。

2.12 日 10:30-16:30
 シンプोजウム講演十パネルディスカッション
 会場◎京都大学百周年時計台記念館1階 時計台記念ホール
 講演 (映像中継あり)
 近藤 圭介 京都大学大学院 造学研究所 准教授 (法哲学)
 稲川 貴大 インターナショナル総合学研究ユニット 特任教授 (宇宙飛行士)
 土井 隆雄 京都大学 宇宙総合学研究所 教授 (水資源工学)
 山敷 庸亮 京都大学大学院 理学研究科 教授 (生態学)
 保尊 隆亨 大阪市立大学大学院 理学研究科 教授、所長 (宇宙工学)
 湯本 貴和 京都大学 豊額研究所 准教授、所長 (宇宙工学)
 稲谷 芳文 宇宙航空研究開発機構 宇宙科学研究所 教授、副所長 (宇宙工学)
 和歌山大学 国際観光学研究センター

参加費無料
 託児室あり

お問い合わせ
 usss@kwasan.kyoto-u.ac.jp
 お申し込みはWEBフォームにて
<https://www.usss.kyoto-u.ac.jp/symposium10.html>

主催◎京都大学 宇宙総合学研究科附属天文台
 後援◎宇宙航空研究開発機構、京都府教育委員会、京都市教育委員会、和歌山大学

月面で地球を見ているアポロ14号クルーのエドガー・ミッチェル (提供: NASA)

A4 チラシ A2 ポスターデザイン

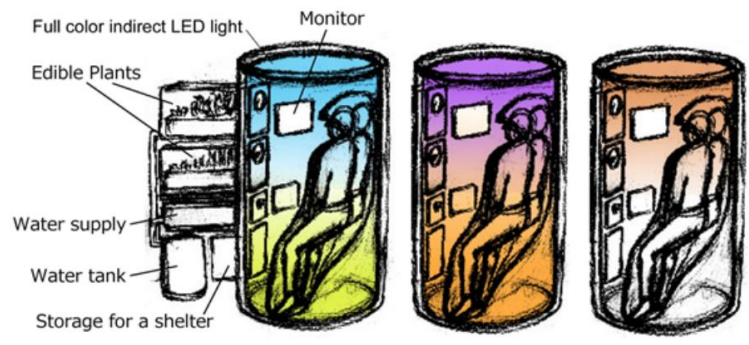

アメリカ人カップルの火星フライバイミッションにて宇宙放射線を避けるシェルター内部で食用植物を楽しみ二人用寝袋で共にモニターで様々なコンテンツを楽しみ内部間接照明の色の移り変わりで時間の変化も感じられるというデザイン案。

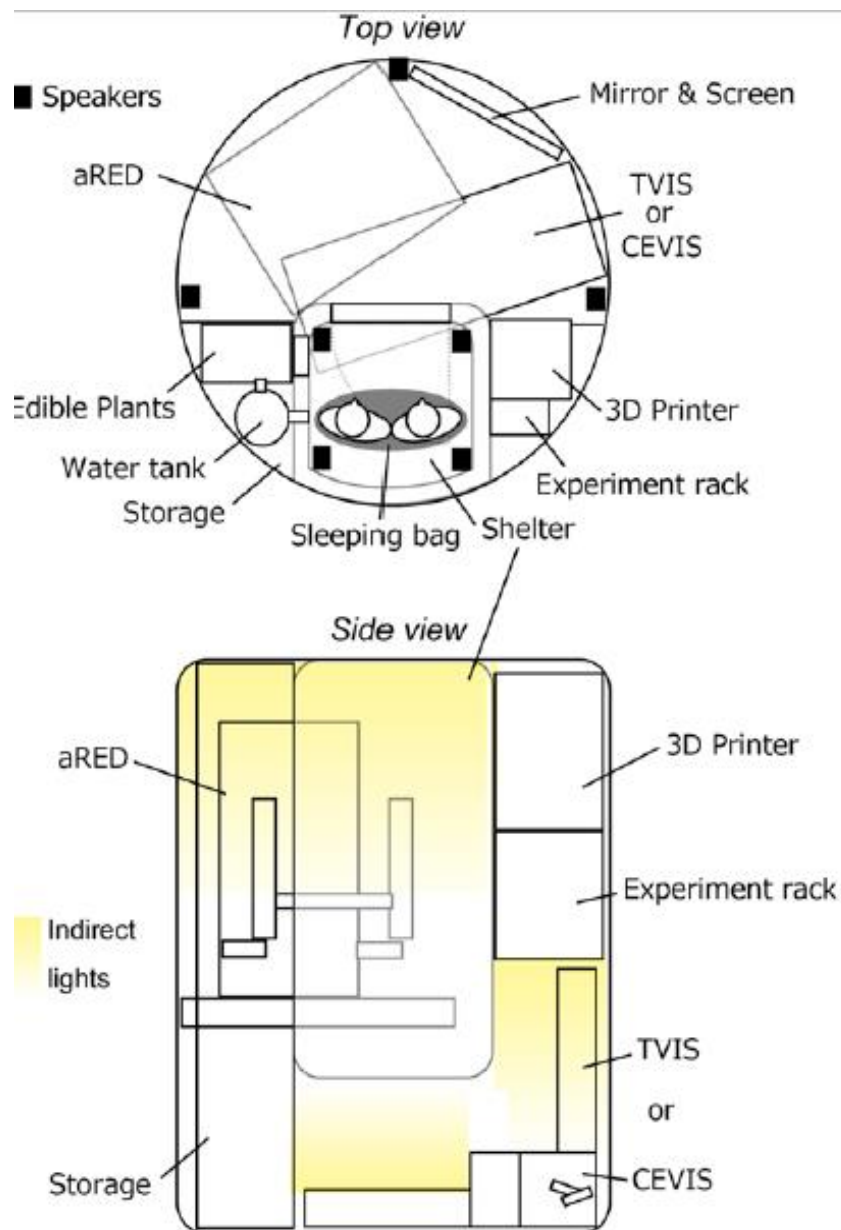

間接照明や広さを感じさせる鏡、その上にスクリーン、撮影や立体音響で映画を楽しむこともできる。日米合同チーム KANAU (協) の火星フライバイミッションの宇宙船デザインコンテストでチームとして優勝した宇宙船デザインの高い評価を得たインテリアデザイン

Maintain Water Balance in Your Body Your Best Travel Partner



+ion

Mariah's News



End AGAIN...then enjoys a late, late, dinner

Last updated at 10:58am on 2nd April 2008

Mariah Carey rounded off a day of promotional duties with a three-hour dinner at celebrity haunt San Lorenzo and caused chaos as paparazzi and fans swarmed the Knightsbridge eatery.

In scenes similar to her appearance earlier in the day at Selfridges, the diminutive diva had to be chaperoned out of the restaurant by her bodyguard, as she was mobbed upon leaving at the late hour of 2.30am.

Arriving at the five-star Baglioni Hotel in Mayfair at 2.30am she ordered her limousine to circle the street refusing to leave the sanctuary of her chauffeur-driven car until a red carpet and scented candles had been laid out for her early morning arrival.



Diva wheels: The taxi which Mariah arrived in bore an advert for her new album



To make her stay as comfortable as possible she booked every penthouse suite in Claridges Hotel in Mayfair.

Even Celebrity chef Gordon Ramsay - who seems to spend more time these days at other people's restaurants telling them how awful their food is - was spotted in his work clothes outside the hotel's Gordon Ramsay restaurant, looking uncharacteristically nervous.

He was no doubt there to make sure everything ran like clockwork for her arrival.

A gym was installed for her week long stay while hampers of fresh fruit have been delivered each morning to her hotel room.

The singer even requested a antique table covered with a silk cloth on which to sign copies of her single. Two hundred and fifty fans queued right through the night outside the store for a chance to see the star but she still kept them waiting for 45 minutes. After a brief wave to the crowd she disappeared into the homeware section where her dedicated team of stylists began retouching her makeup. However the singer dismissed her reputation as a diva by saying: "I just put it all, on it's just fun and games. People take it so seriously and they expect me to be a certain way.

"If people don't get my sense of humour by now they never will. I truly am just a normal person, I just want to have fun and make music.

"If you never lose who you are prior to the fame then that's how fans relate to you. That's why my fans are so dedicated."

Only hours after flying into the capital on Monday the star unleashed a diva tantrum.

Radio One DJ Reggie Yates was the first - and surely not the last - to get on the wrong side of Carey's notoriously volatile temper.

During a telephone interview she slammed down the handset mid-conversation after the DJ had the audacity to claim she had only sold 80 million albums instead of 165 million.

While "Side Effects" features Young Jeezy, it sounds like a rock power ballad, as if Mariah had been listening to a lot of Bonnie Tyler and Pat Benatar and decided that to capture her emotions, the music needed to share her pain. This turns out to be a good thing, because when she's not focused on vocal gymnastics, Mariah can really sing - as in, letting us really feel what she feels. Nowhere else on the album does Mariah get quite so emotionally naked, and it makes you wonder: What would Mariah have sounded like if she ventured out of her comfort zones of pop and R&B? (Notwithstanding her ill-advised Def Leppard cover, of course.)

While "Side Effects" is about her ex-husband, her second single, "Bye Bye,"

appears to be about her late father, Alfred Roy, who died of cancer in 2002. Mariah reminisces about the too-little time she shared with her mostly absent father and regrets how as a child, she didn't understand why he failed

to show up sometimes to see her after he and her mother divorced when she was 3. But mostly Mariah regrets that he "never got a chance to see how good I've done/ And you never got to see me back at #1." This confessional moment doesn't last long, since she extends this song about death to be for anybody "who just lost somebody."

But for most of E=MC2, Mariah doesn't want to feel any pain - she wants to party the night away. So on the club-thumping "Migrate," she hops from "my car into the club ... from the bar to VIP ... from the party to the afterparty ... afterparty to hotel!" with T-Pain, who urges her to "bounce, bounce, bounce." Like most MC albums, every guest star seems required to check her name at the door, and this is no exception. "Migrate," which was co-produced by Nate "Danjahandz" Hills, has Mariah in full diva mode as she leaves a club once they start "playing my jam."

Just in case there was a question of which jam that might be, she name-checks them herself in "For the Record," a play on words in which she incorporates past song titles into a verse after she asks her lover, "Give me one reason one we can't just press rewind?"

"I'm That Chick" ups the ego ante, but as she demonstrates with some silly lyrics ("la da da ooowee") and a funky disco beat (benefiting from an "Off the Wall" melody sample), she's not taking any of it seriously. At

least we hope she's not serious when she compares herself to Tupac and Biggie, then ice cream and the lottery, as she softly taunts, "You're fiending to blaze up and taste me." As if this weren't already destined for the '80s time-warp roller-disco crowd, she serves up the joyful romp "I'll Be Lovin' You Long Time," which borrows from the chorus of DeBarge's "Stay With Me" (as well as a phrase uttered by a Vietnamese hooker in "Full Metal Jacket" and then sampled by 2 Live Crew and other hip-hop

acts). At least on the reggae-inflected "Cruise Control" (featuring Damian Marley), she exhibits a sense of humor, singing in a Jamaican patois during the second verse: "When tha door open, de gals on de block they be hopin' to rob tha clock." She's not joking, or as she puts it, "Tink I'm joking?"

But for all the jokes, silliness and absurdities, Mariah is at her best when she keeps it simple, as she does in the closing track, "I Wish You Well," a piano ballad with gospel overtones (even including Bible verses from the books Proverbs, John, Philippians and Psalms). The song is a turning-of-the-cheek to anyone who mistreated her or doubted her. Older and wiser, she realizes on E=MC2, which hits stores April 15, that she needed them all along to make her who she is now, and thanks them for it. Because if she can be square with them, she's truly set free - squared.

--By Jennifer Vineyard





ISU SSP 07

Space Traffic Management

Executive Summary

Authors

- | | | | |
|---|---|---|--|
|  | Anilkumar AK, <i>India</i> |  | Xavier Michalski, <i>France</i> |
|  | Satoru Aoyama, <i>Japan</i> |  | Ayako Ono, <i>Japan</i> |
|  | Ben Baseley-Walker, <i>United Kingdom</i> |  | Angeline Asangire Oprong, <i>Kenya</i> |
|  | Karl Bilimoria, <i>United States</i> |  | Sascha Pillokeit, <i>Germany</i> |
|  | Cian Curran, <i>Ireland</i> |  | Kevin Shortt, <i>Canada</i> |
|  | Karina Drees, <i>United States</i> |  | Tim Smallhorn, <i>Australia</i> |
|  | Donato Giorgi, <i>Italy</i> |  | Erin Tegnerud, <i>United States</i> |
|  | Evelyne Greneche, <i>France</i> |  | Antonio Yukio Ueta, <i>Brazil</i> |
|  | R. Brogan Hetrick, <i>United States</i> |  | Meritxell Viñas Tío, <i>Spain</i> |
|  | Muchun Jing, <i>China</i> |  | Brian Weeden, <i>United States</i> |
|  | Richard B. Leshner, <i>United States</i> |  | Weibin Gao, <i>China</i> |
|  | Xuejun Liao, <i>China</i> |  | Weiguo Shen, <i>China</i> |
|  | Kenta Maruyama, <i>Japan</i> |  | Ole Kristian Western, <i>Norway</i> |
|  | Ricardo Marvao, <i>Portugal</i> |  | Guangming Zhang, <i>China</i> |
|  | Lex Meijer, <i>Netherlands</i> |  | Jhony Zavaleta, <i>United States</i> |

Sponsors

-  National Aeronautics and Space Administration (NASA)
Ames Research Center
- The Arsenault Family Foundation
- International Association for the Advancement of Space Safety (IAASS)



Space Traffic Management
ISU SSP 07 Beijing



Space Traffic Management Executive Summary

ISU SSP 07





ヴィクトレックス社 IH プロテクト・マットのデザイン

Illustrator

Zen Gardens on Earth's Moon & Mars

MA Fine Arts, Ayako Ono
(Artist in Residence at ESA)

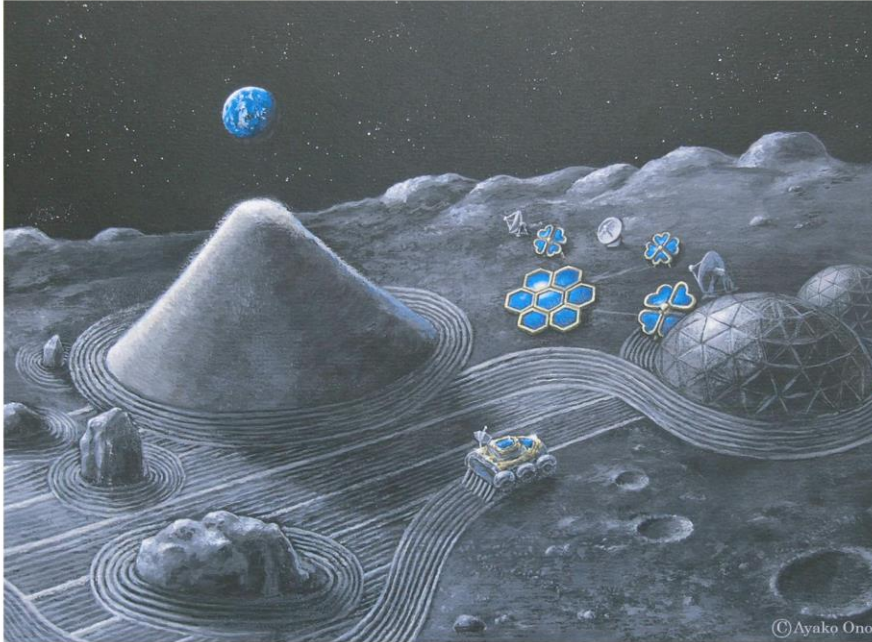

Mt. Fuji shaped Kougelsudai at Ginkakuji Temple, a Zen Temple, was established in 15th century.



An innovative design to enjoy the reflection of moonlight and to feel the pretty view with the moon placed above the mountain.

The Zen Garden style called "kareansu" literally means "dry landscape." The main elements of kareansu are rocks and sand that engender calmness by symbolizing the sea and the water stream as minimal compositions.

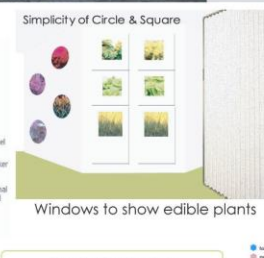
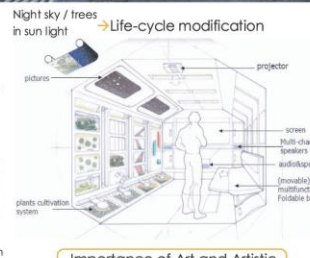
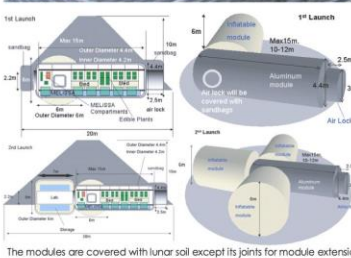

Natural Design (Zen Garden is the Application)

- A discipline based on naturally occurring phenomena involving the natural elements.
- It aims to create a context of art and design interactions to increase the psycho-physiological well-being of humans.

Importance of Art and Artistic Design in Space Architecture

- Severely long duration missions Moon (by 2020), Mars and beyond
- Reduce crew's stress levels and enhance their working capability
- Development of space tourism for the general public
- Adding value with arts and architecture
- Concrete examples: Ingenuity for design
- Land art and architecture: TOURIST ATTRACTION

Key Design Factors

Perception	Contribution
Visual	• Color effect
Auditory	• Indirect lighting
Small	• Fractal landscape
Tactile	• Landscape with natural materials
	• Edible plants as foliage
	• Audio system (soundscape design)
	• 1/2 noise and noise reduction
	• Utilization of 1/2 noise for devices
	• Aroma therapy
	• Soft & elastic materials
	• Comfort

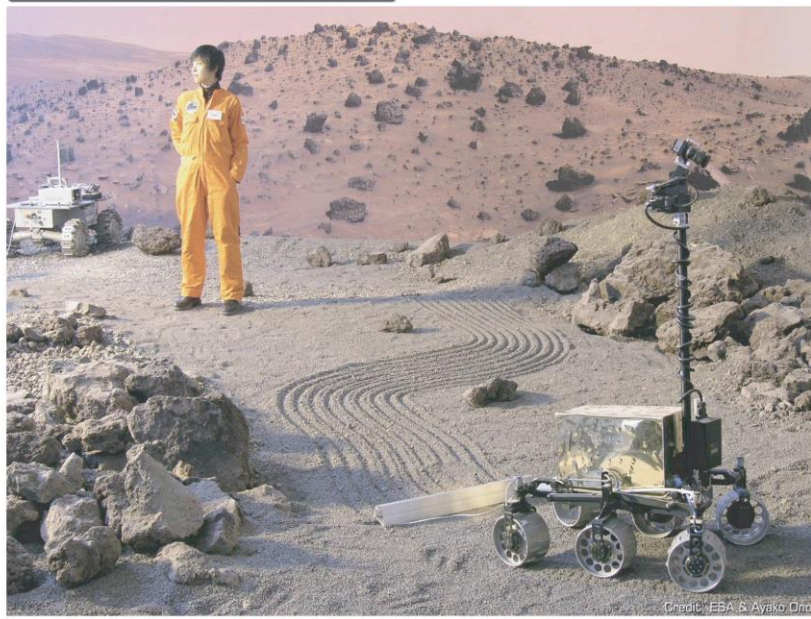
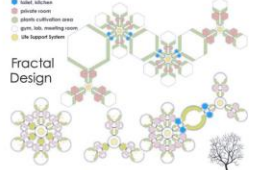

Humanizing the outer space environment through the use of Space Art

- Artistic design could be a tourist attraction, at the same time helping astronauts/cosmonauts
- A little ingenuity could be an effective contribution for human life and well-being
- The detail of the design is also important to advancing the nice environmental design
- Using essential elements as materials in artistic expression to cut costs

Acknowledgment
Special thanks for the support and inspiration to:
Mr. Dieter Isakelt (Head of the ESA/ESRIN Corporate Communication Office) and Dr. Bernard Foing (ILEWG Executive Director, ESA Chief Scientist),
Erasmus User Centre of ESA / ESTEC
Mr. Willem van Hoogstraten for the device to rake sand, Mr. Massimo Sabbatini and Ms. Melanie Cowan for the filming and the other assistance.
ESA Automation and Robotics Lab.:
Dr. Gianfranco Visentini, Mr. Panfili Poulakis, Mr. Andre Schiele, Mr. Maurizio De Bartolomei, and Mr. Luc Joudrier,
Hilton Sorrento Palace's people for the simulation of Lunar Zen Garden at the hotel, in particular the manager, Giovanni di Maio, Salvatore Pollio, and all the people involved because of their kindness.
ELETEC Co., Ltd. CEO, Junichi Kikahara for the assistance of solar panels' shaping, and Shizennokaze operation director, Masanori Okuda for solar energy kit, Prof. Hideki Minoura at Gifu University for the colorful solar panel "Rainbow Cell".
Prof. Melchiorre Masali at University of Turin for the advices, Dr. Christophe Lasseur and Mr. Pierre Rebeyre of MEUSSA Project (URL: <http://eclis.eu/en/it/eclis/>), Ms. Naoko Hatanaka, Dr. Yong Kyu Cho, and Ms. Chikara Nagakawa for developments.
Habitability for the Extreme Environment
EXTREME DESIGN
www.extreme-design.eu
MA Des., Irene Schlicht (technische Koordinatorin) Irene.Schlicht@gmail.com
MA Fine Arts, Ayako Ono (Artist in Residence at ESA) spaceart21@gmail.com

A0 サイズ ポスター

Photoshop, Illustrator



花型ソーラーパネルのデザイン

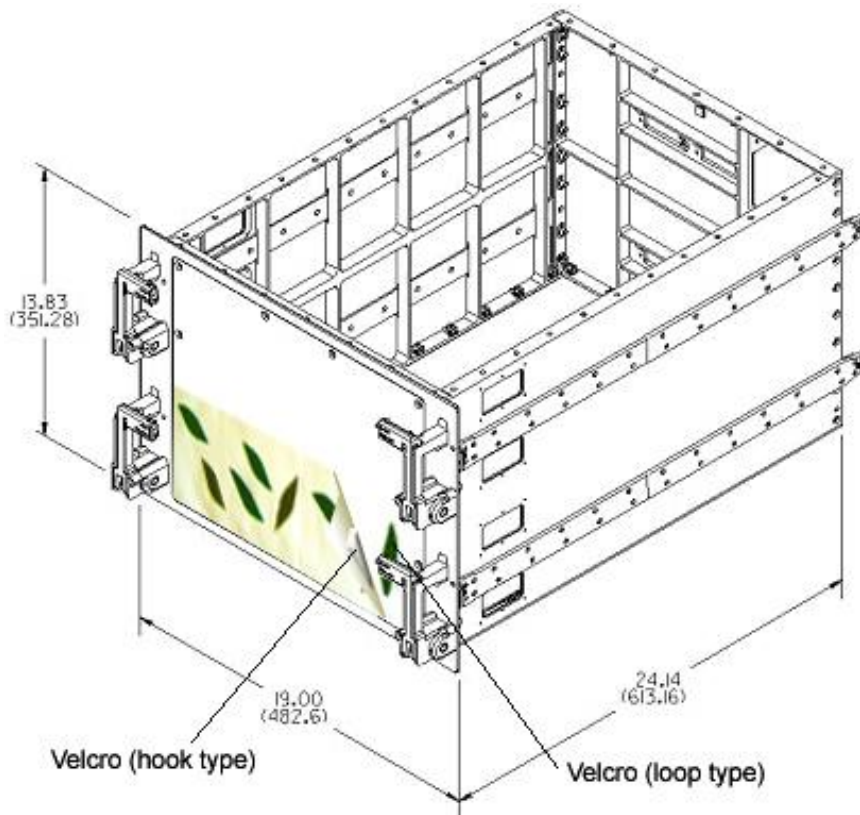

葉型マジックテープを付けたポケットの説明図（無重力環境のためのデザイン）

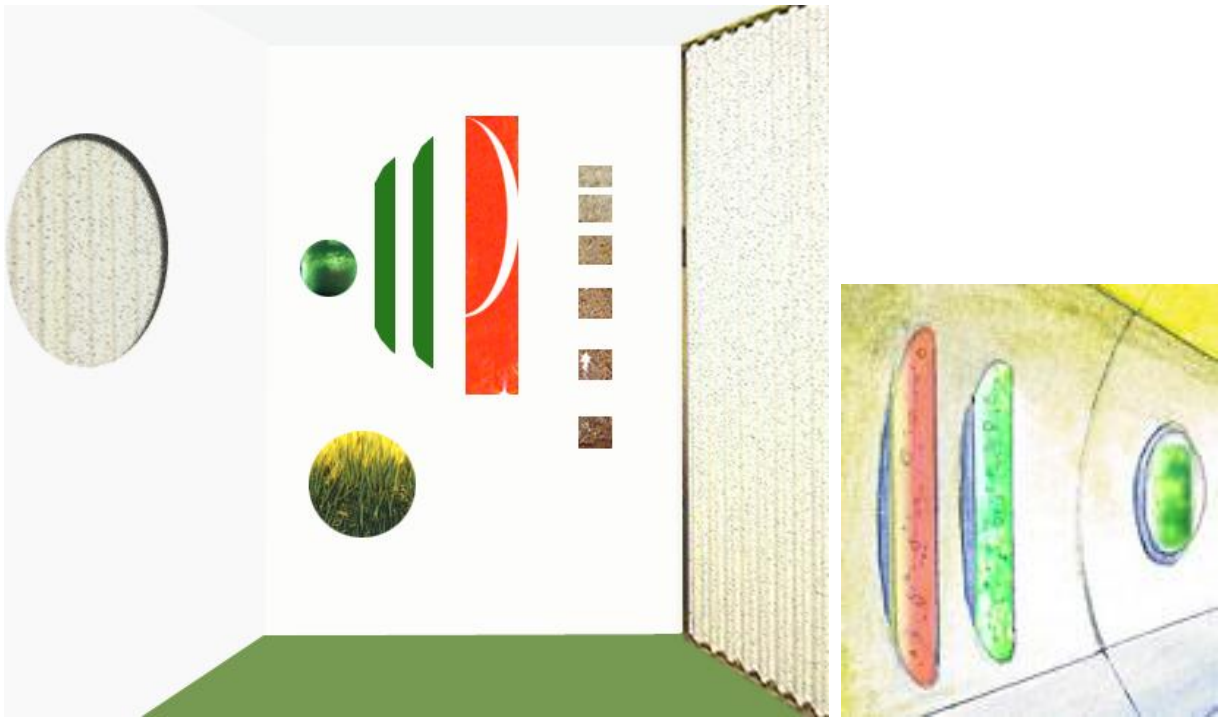

生命維持装置のバクテリアが入っているカラフルな容器を見せるデザイン

Photoshop, 手描き



宇宙での植物栽培エリア(食用植物を観葉植物のように見せる壁面デザインの提案)

Photoshop



jse

ロゴマークデザイン

Illustrator

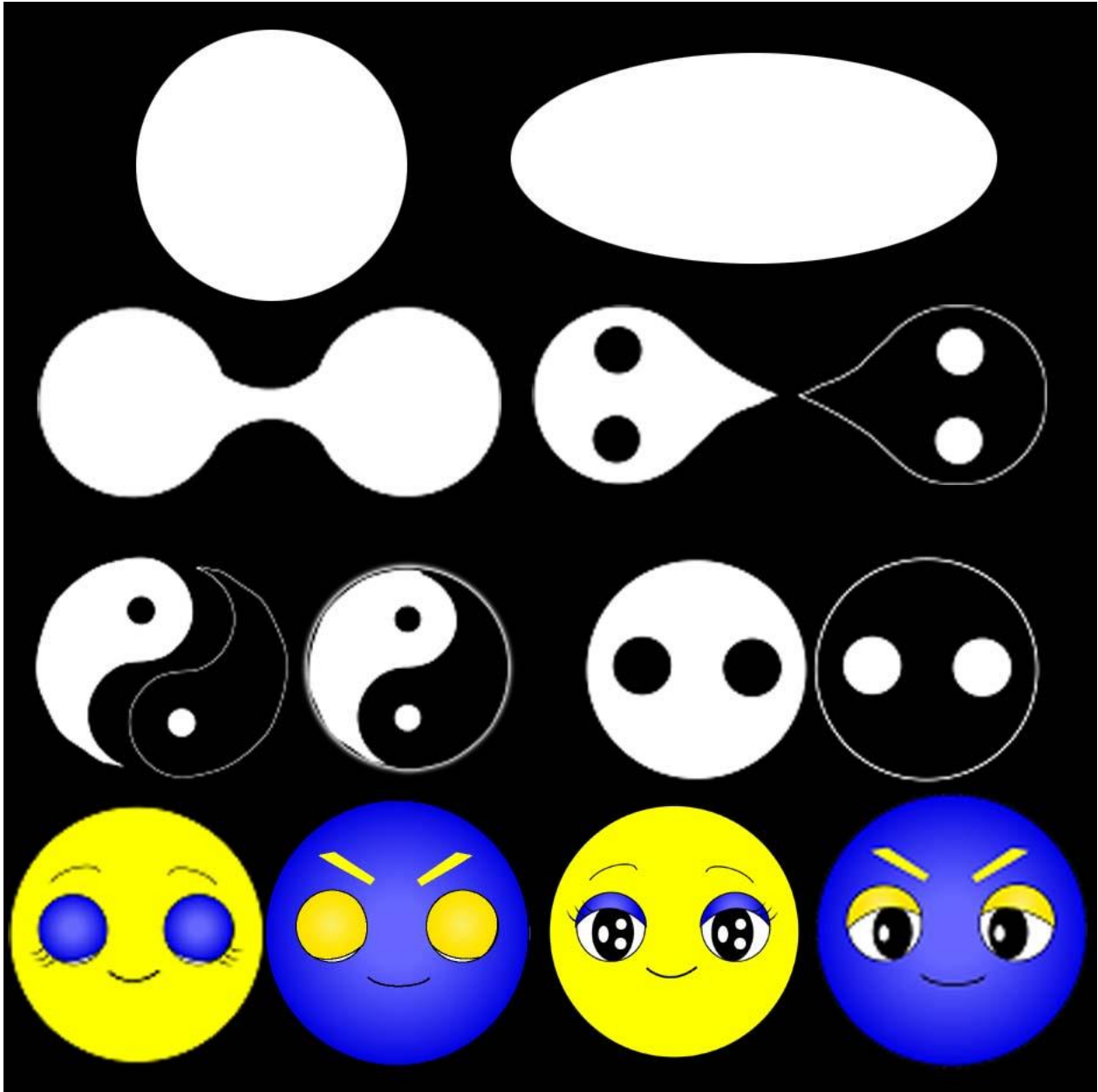

キャラクターデザイン

Illustrator



A0 サイズ / ポスター・デザイン

Photoshop

Illustrator



表紙デザイン

Photoshop, Illustrator

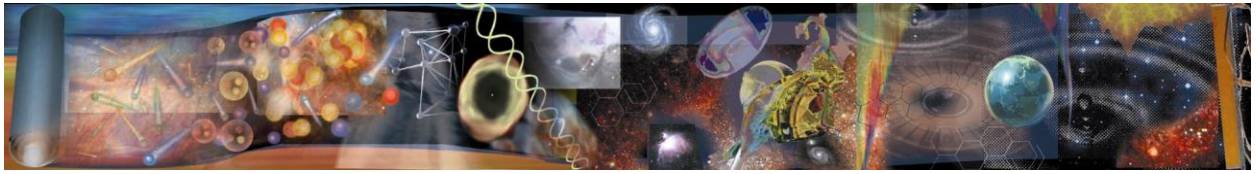

壁面用：宇宙の歴史を絵巻物のように表現

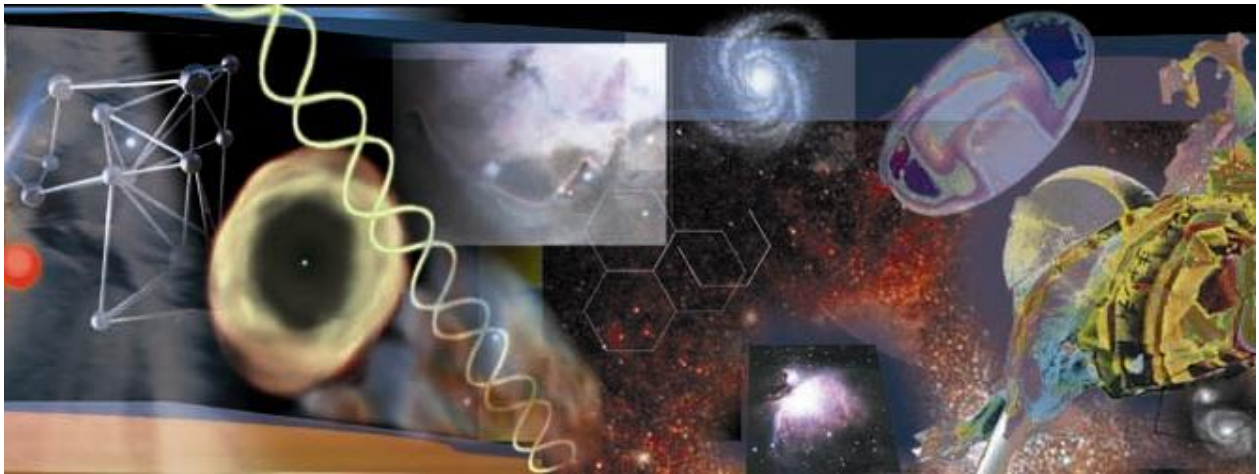
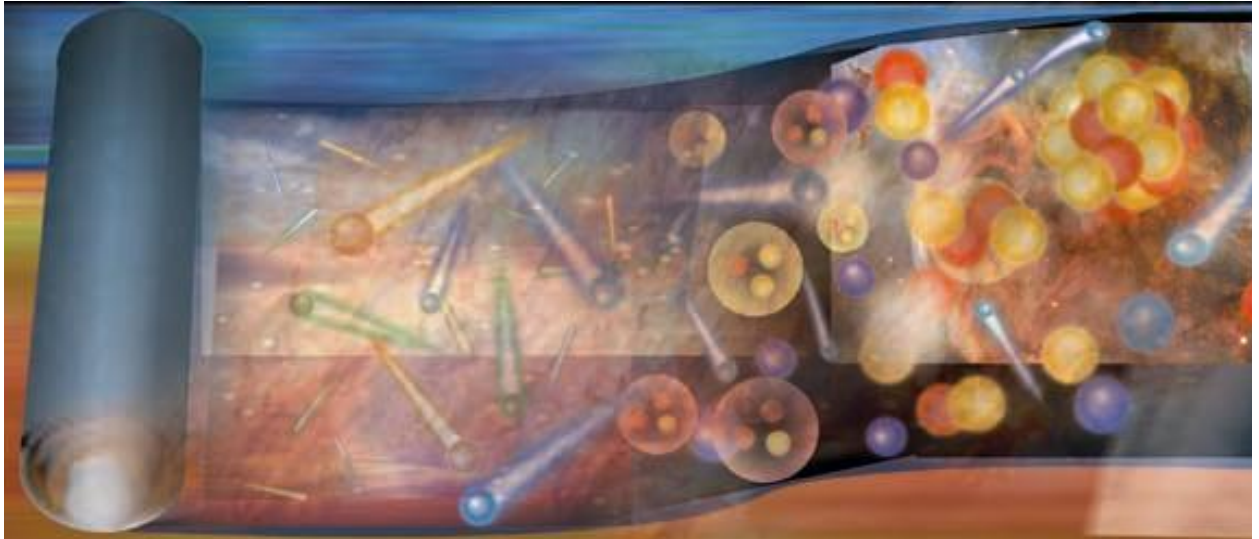

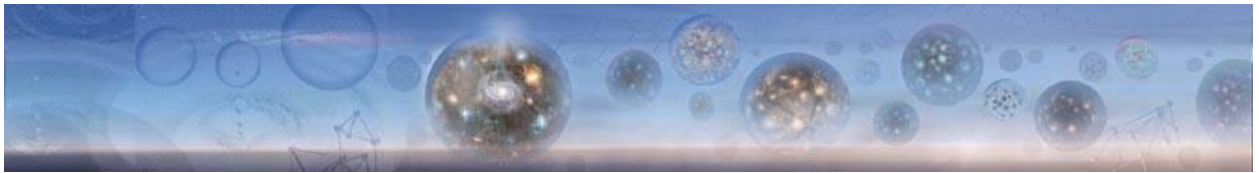

幾つもの宇宙を表現

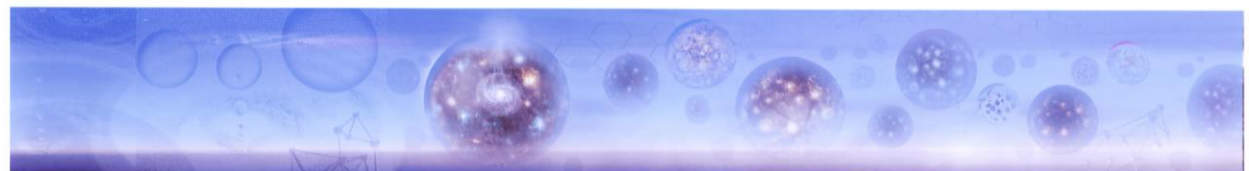
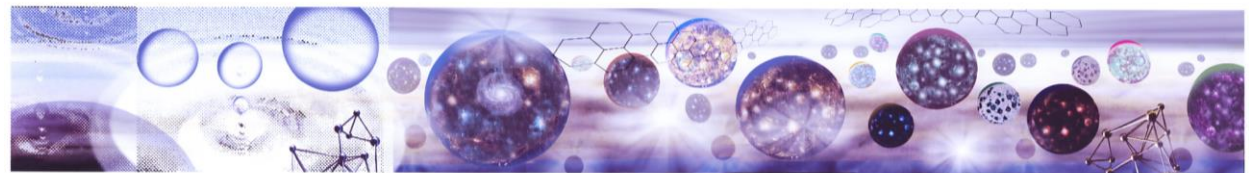
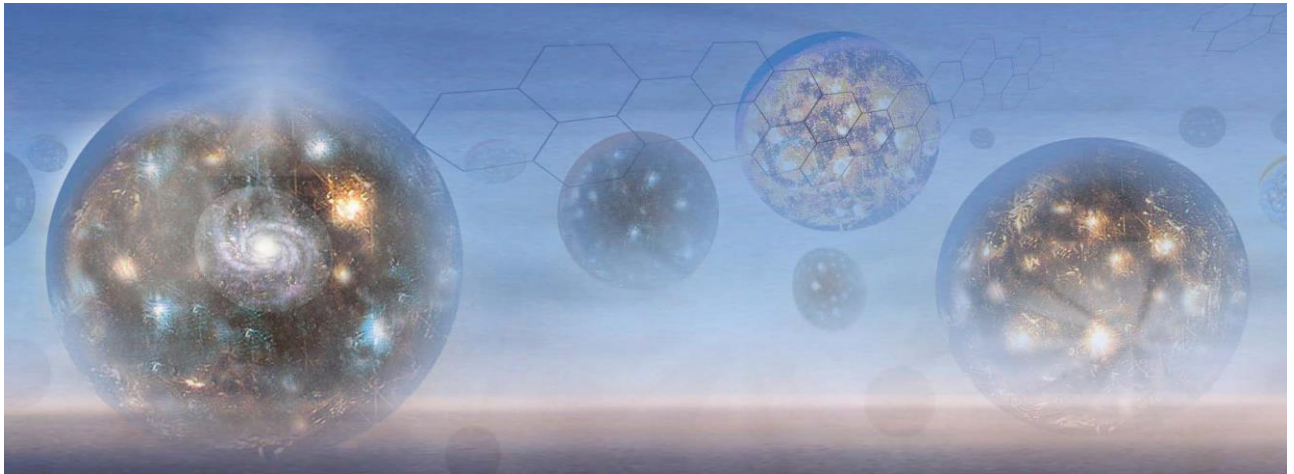

宇宙研(JAXA/ISAS)
Tシャツデザイン

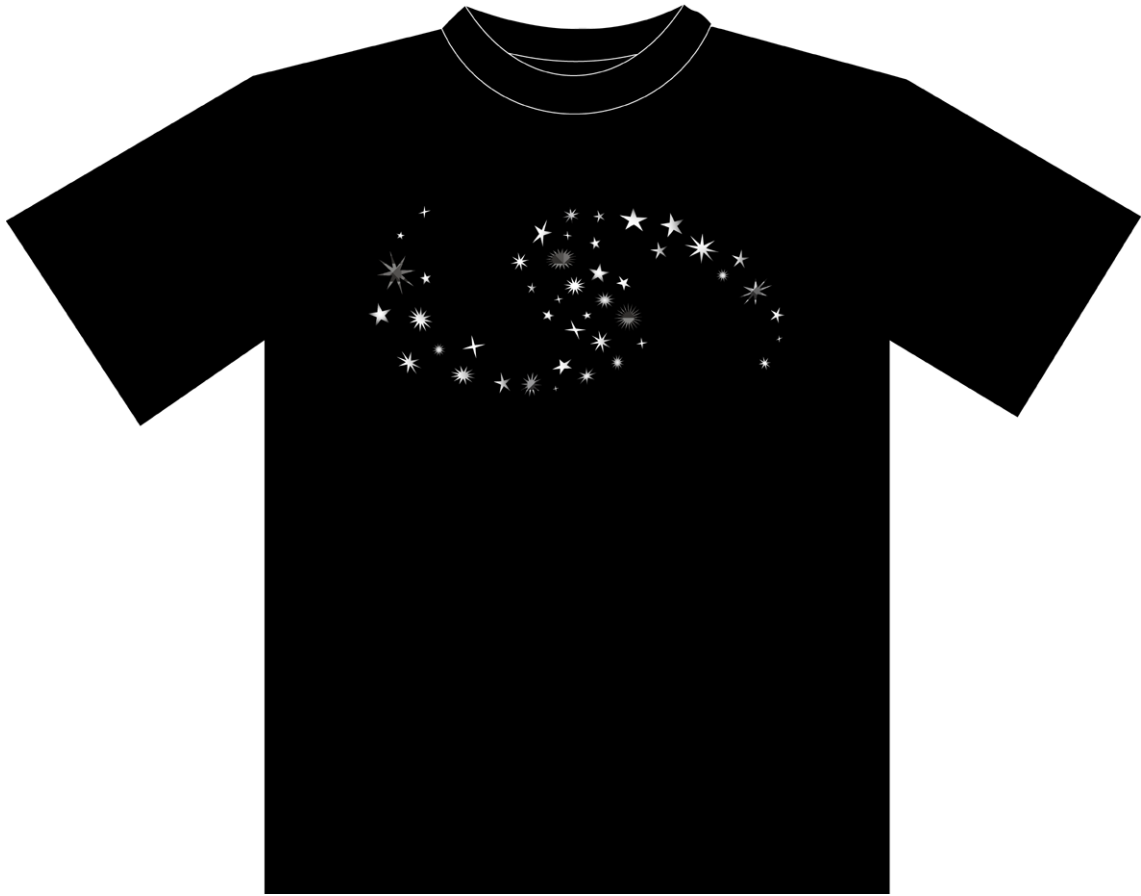



ASTRO-F : Making Cool Maps of our Universe!

ASTRO-F : Making Cool Maps of our Universe!

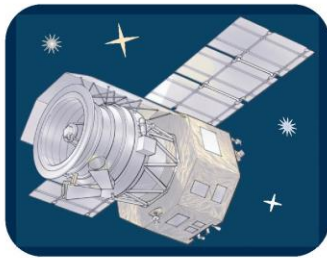

ロケットデザイン

Photoshop, Illustrator

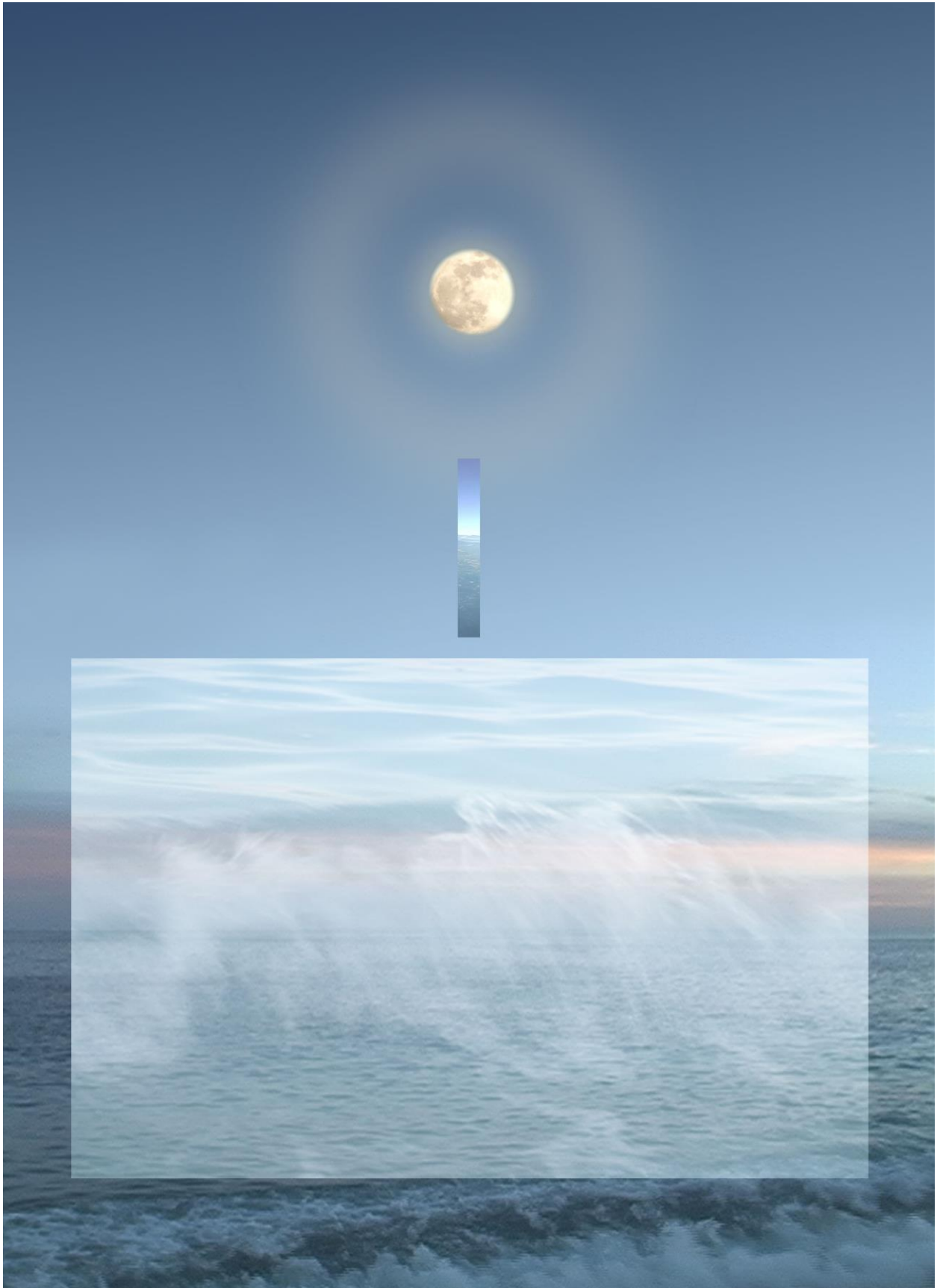

ポスターのためのデザイン

Photoshop

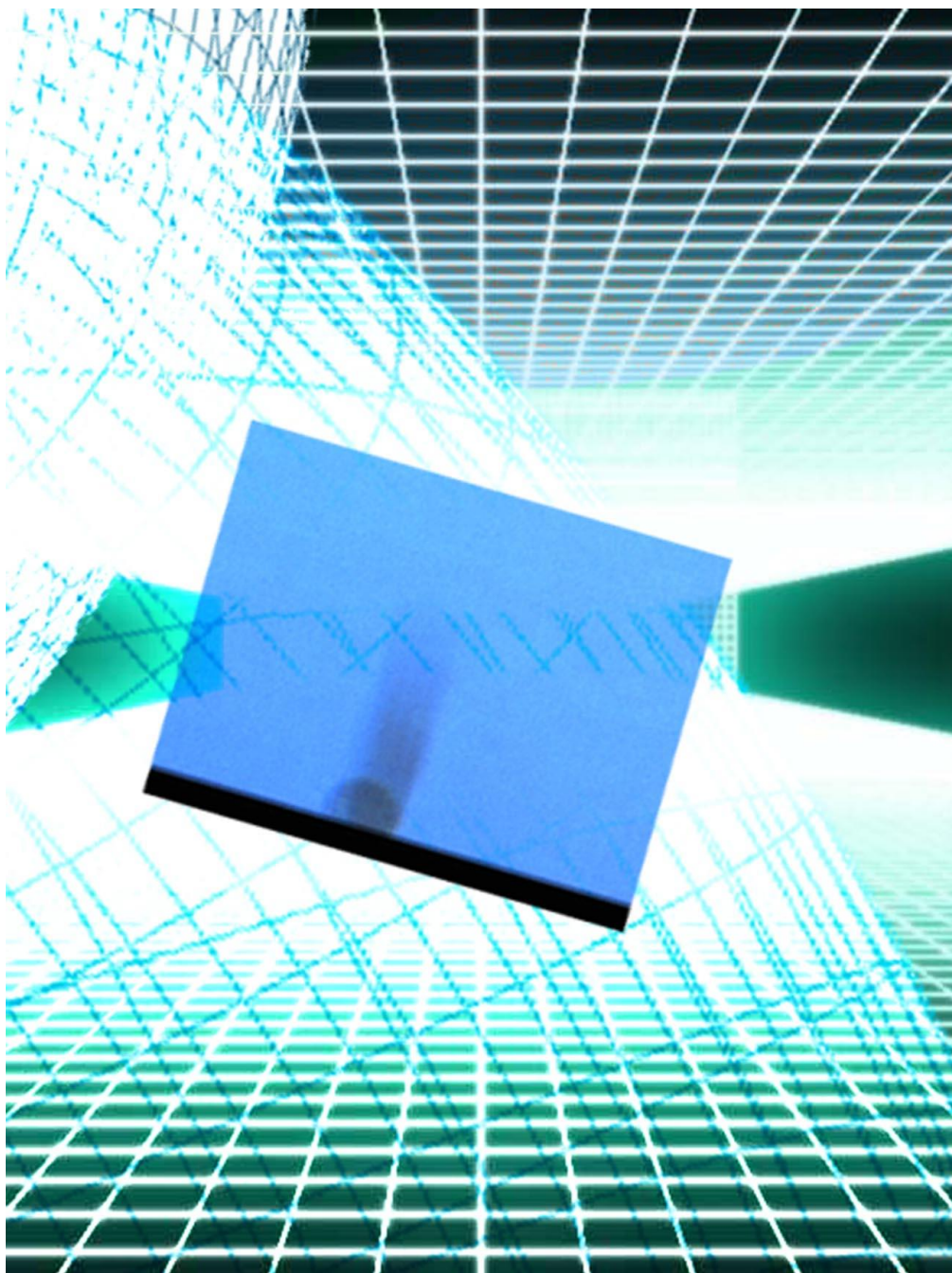

DM のためのデザイン

Photoshop
LightWave

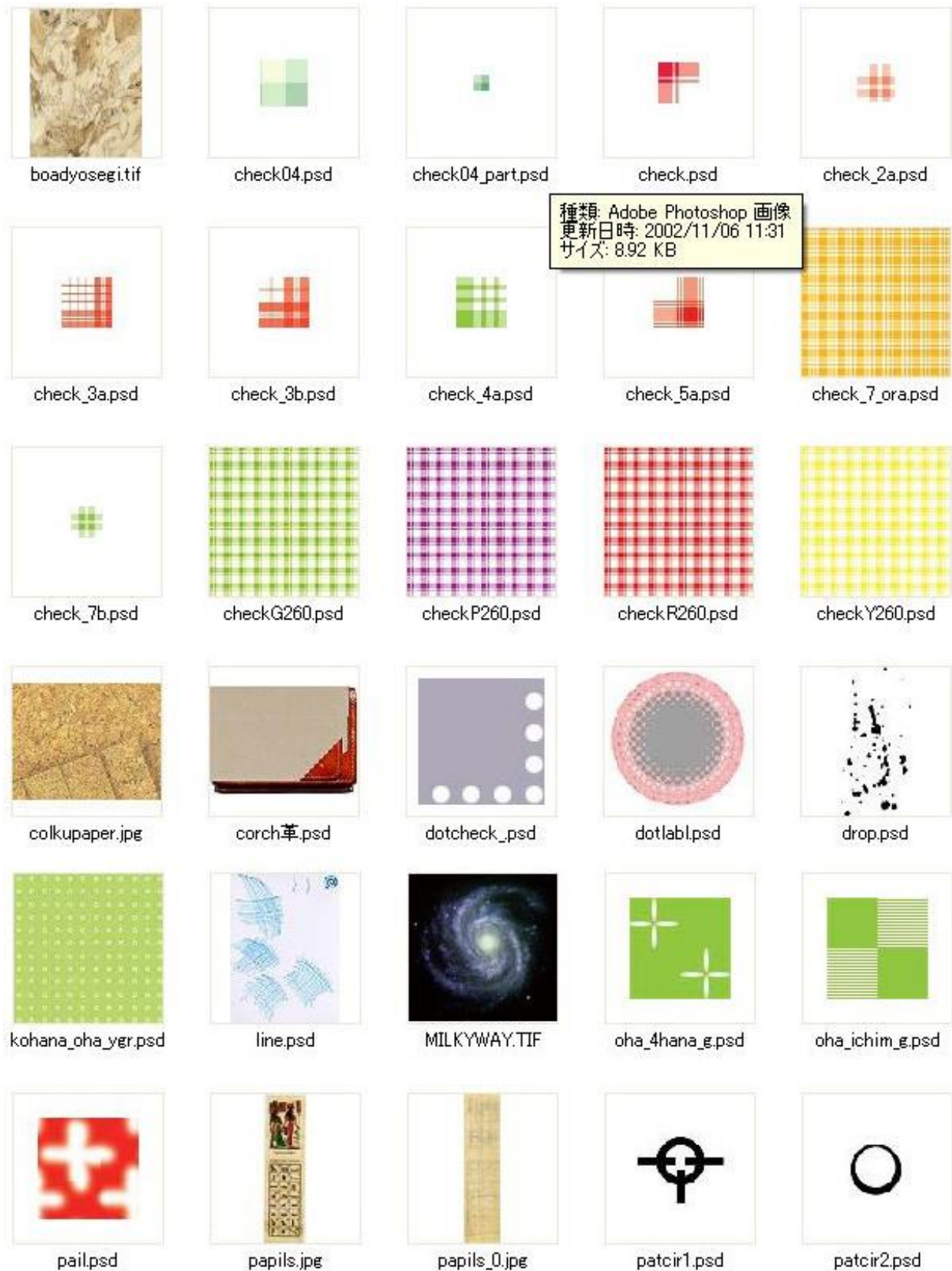

日本製箔株式会社でのテクスチャーのデザイン

Photoshop
Illustrator



galaxy.PSD



hana1.psd



hana2.psd



hisi8mot.psd



hisi.psd



Japanplant.psd



kawahaich.psd



kawamot.psd

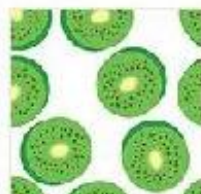

kiwi_pat.psd



kohana_oha_pnk.psd



patfish.psd



patwav2.psd



patwav3.jpg



patwav3.psd



patwav.psd



sasa.psd



sasamot.psd



scanclothmot.psd



siborimaru.tif



siborimarudai.tif

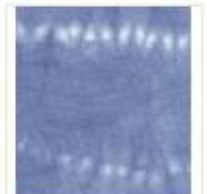

siborisen.tif



spiral.psd



stars0.PSD

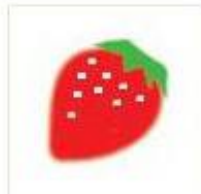

strawberry.psd



strawberry_pat.psd



tail_mot1.psd

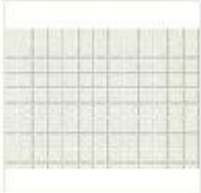

tail_mot.psd



temari_mot.psd

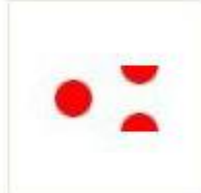

TEX水玉2.psd

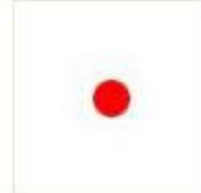

TEX水玉.psd

日本製箔株式会社でのテクスチャーのデザイン

Photoshop
Illustrator



tiedie_tex.psd



ume.psd



wamame.psd



wamame_pat.psd

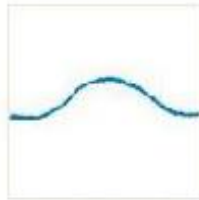

waveline.psd



yogore1.psd



yogore2.psd



yogore3.psd



yogore4.psd

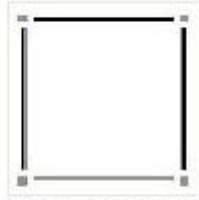

デザインタイル1.PSD



革.psd

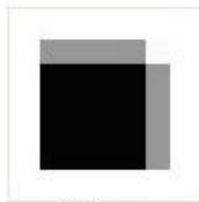

錯視.psd



縦線ランダム.TEX.psd

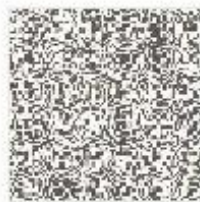

石タイル.PSD

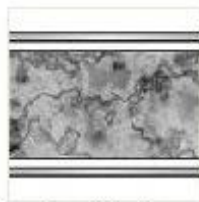

壁シート一部タイル1.psd



配置 1.jpg



pattern3.psd



木タイル.PSD



木目タイル右.PSD



木目タイル左.PSD



check1a.psd



check1b.psd



check2c_a.psd

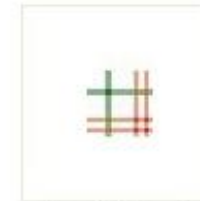

check2c_b.psd

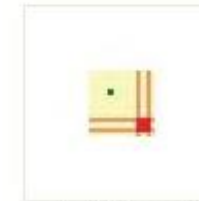

check3c_a.psd



check04_part.psd



check_7b.psd



check_8.psd



check_8b.psd



dairisek.i.psd

日本製箔株式会社でのテクスチャーのデザイン

Photoshop
Illustrator

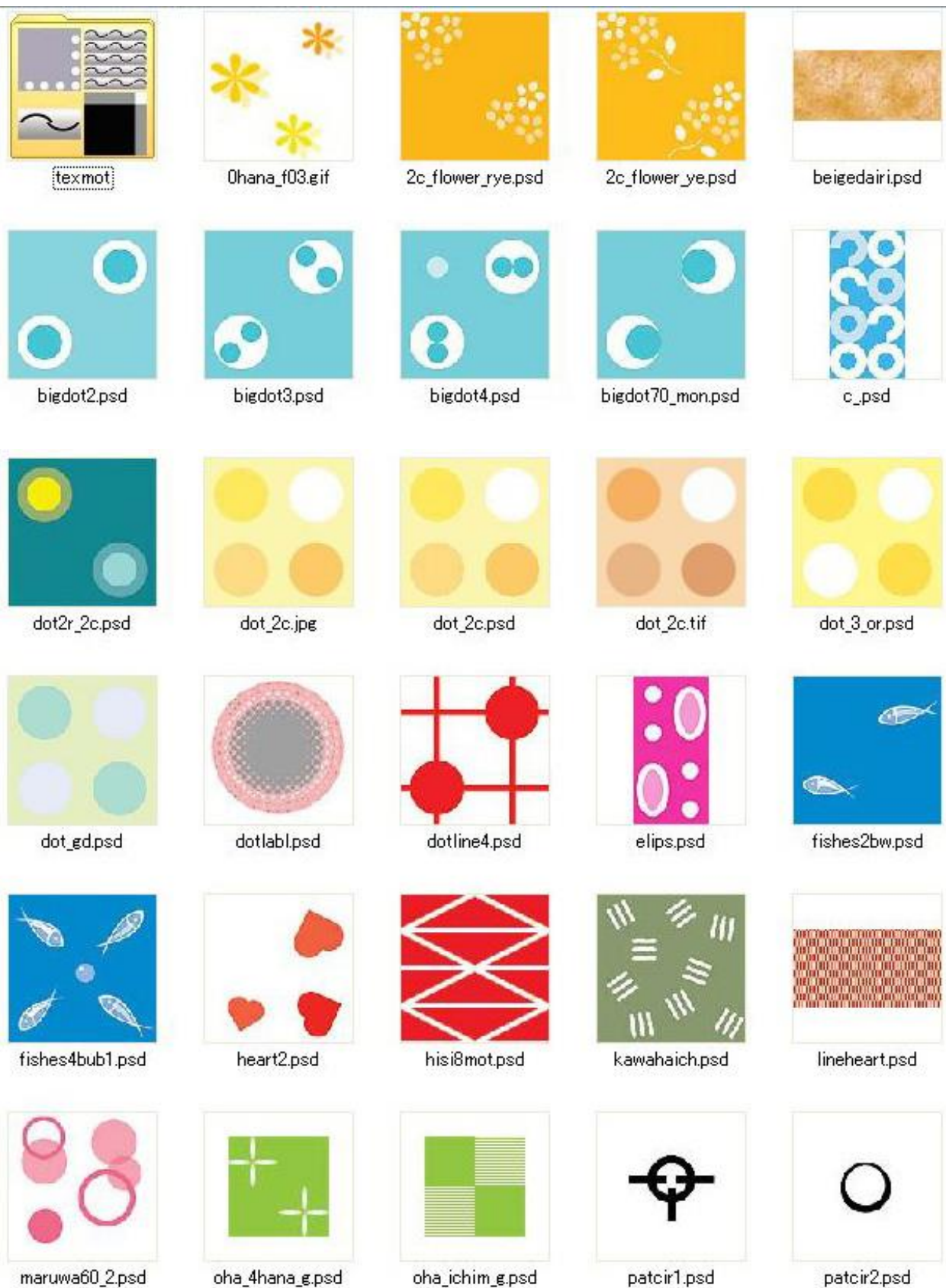

日本製箔株式会社でのテクスチャーのデザイン

Photoshop
Illustrator

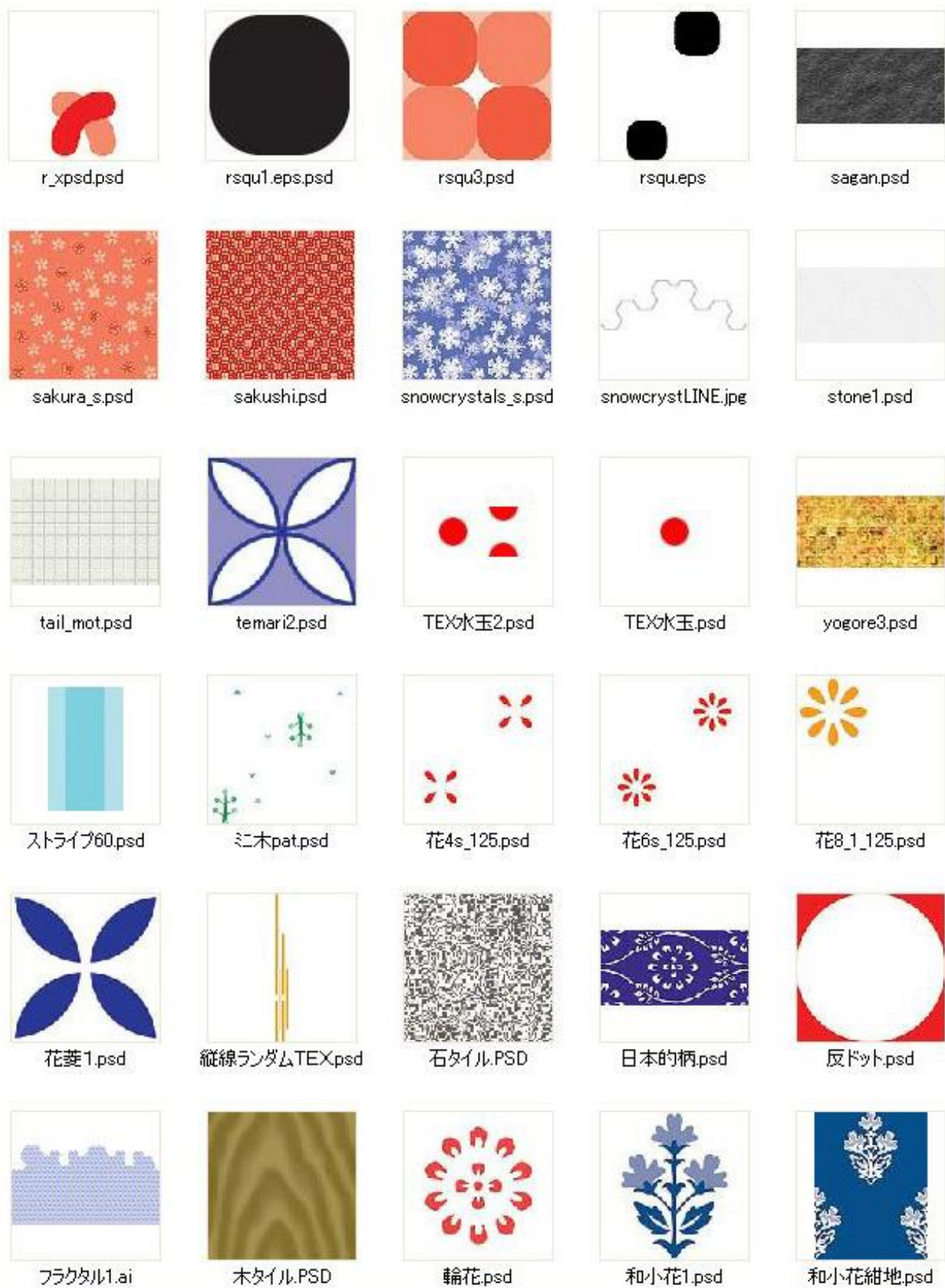

日本製箔株式会社でのテクスチャーのデザイン

Photoshop
Illustrator



new

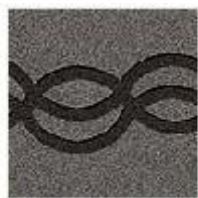

stone7.psd



stonesheet1.psd



stonesheet3.psd

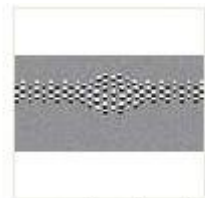

stonesheet4.psd



stonesheet5.psd



stonesheet6.psd



stonesheet7.psd

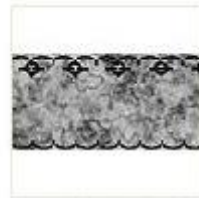

stonesheet8.psd

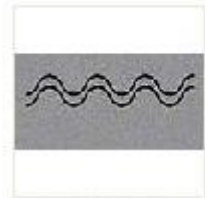

stonesheet.psd



ハートカラフルシート.psd

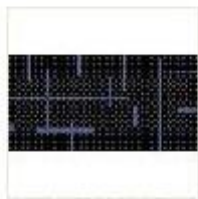

モダンライン青点.psd



星黄シート.psd



大理石621A.psd



大理石621E.psd



大理石621C.psd



大理石波.psd



輪橙.psd



壁シート一部タイル
1.psd



壁シート一部タイル1.psd



6TEX



wave1.psd



tex



wave_mot.psd

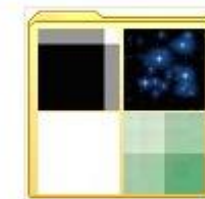

texmot

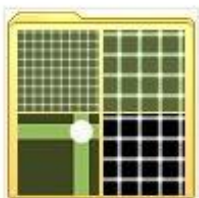

錯視



deimos.jpg



hibiskin.psd



mars.jpg



phobos.jpg

壁用シートのデザイン案と 3DCG・アニメーション用パーツ・デザイン

Photoshop
Illustrator

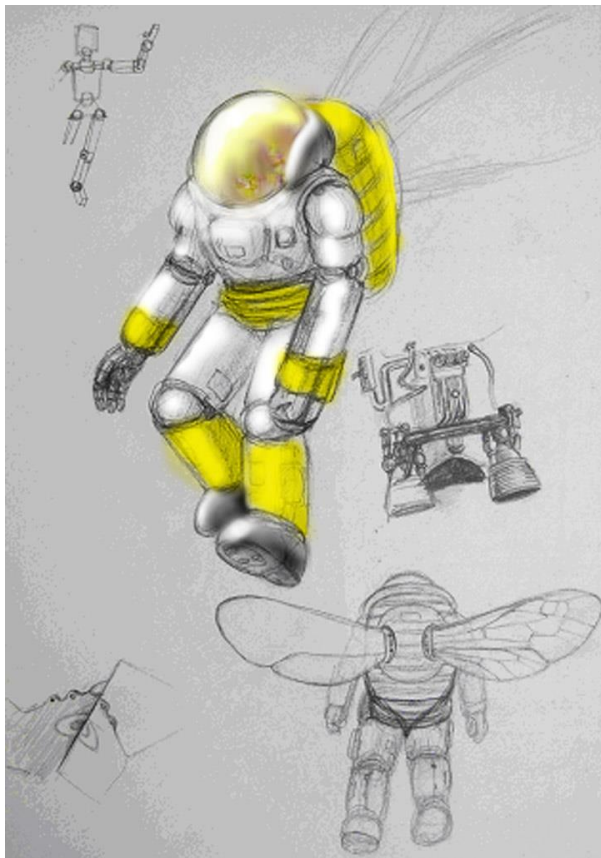

キャラクターデザイン: 宇宙蜜蜂

手描き

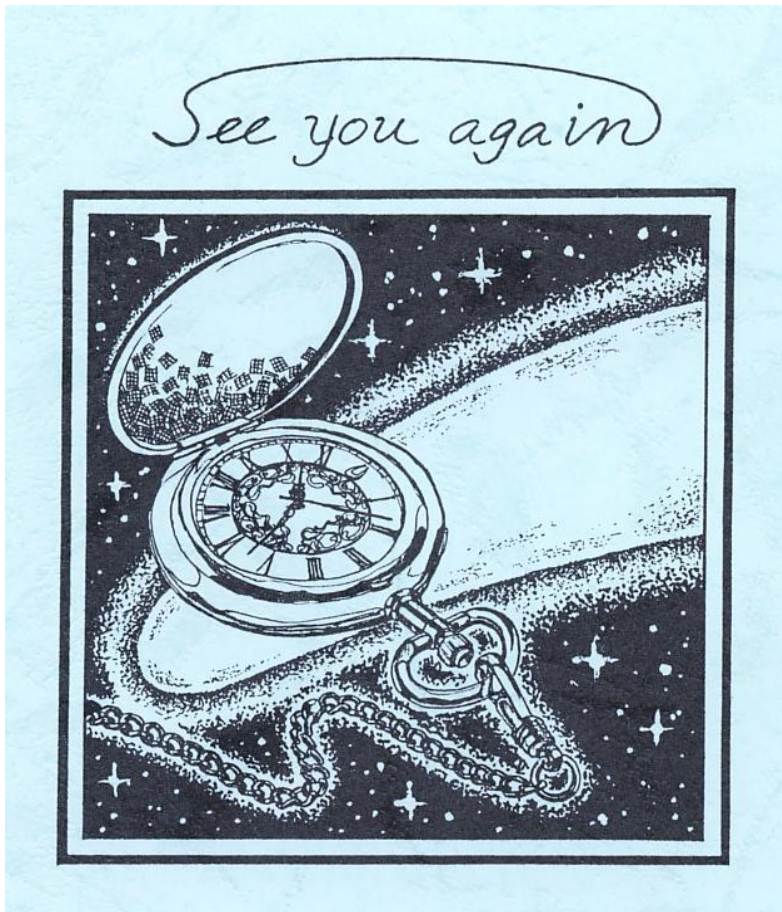

卒業新聞集 裏表紙

中学3年

手描き

サンディーエ株式会社 代表取締役 小野 綾子

略歴

大手ゲーム会社で3DCG デザインおよび2D デザインを習得。

東京藝術大学 大学院 美術研究科 油画専攻 修了後、日本製箔株式会社で4年間のパッケージデザインおよび製品デザインを経てフリーランスとなりました。留学で欧州宇宙機関 (ESA) 初のアーティスト・イン・レジデンスとして、宇宙食パッケージ改善案や国際宇宙ステーションインテリア改善案、芸術的デザイン案等の提案をしてきました。

2011年、国際宇宙ステーションに打ち上げられた無重力状態を活かした金属楽器『宇



宙楽器』を学生としては初のプロジェクト代表として金属彫刻家 根岸 創 氏と共同制作。日米合同チーム KANAU (協) の火星フライバイミッションの宇宙船デザインコンテストでチームとしての優勝にインテリアデザイナーとして大きく貢献しました。現在、会社設立後は見た目に宇宙だったり宇宙食開発にも携わり食の開発とデザイン業務も行っています。